

GENOMIC ADAPTATIONS OF DOMINANT SUGARCANE FERMENTING YEAST STRAINS



Boris Stambuk
Departamento de Bioquímica
Universidade Federal de Santa Catarina



WFCC

WORLD FEDERATION FOR CULTURE COLLECTIONS

ICCC-12 Conference 2010

Biological Resource Centers: gateway to biodiversity and services for innovation in biotechnology



Sustainability and Energy

PERSPECTIVE

Ethanol for a Sustainable Energy Future

José Goldemberg*

9 FEBRUARY 2007 VOL 315 SCIENCE www.sciencemag.org

BUSINESS FEATURE

NATURE | Vol 444 | 7 December 2006

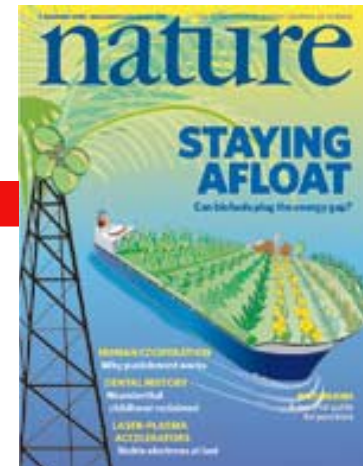

Drink the best and drive the rest

Brazil's sugar-cane ethanol industry is the world's best and able to get better, says **Emma Marris**.

NEWS FEATURE

NATURE | Vol 451 | 21 February 2008

NATURE | Vol 451 | 21 February 2008

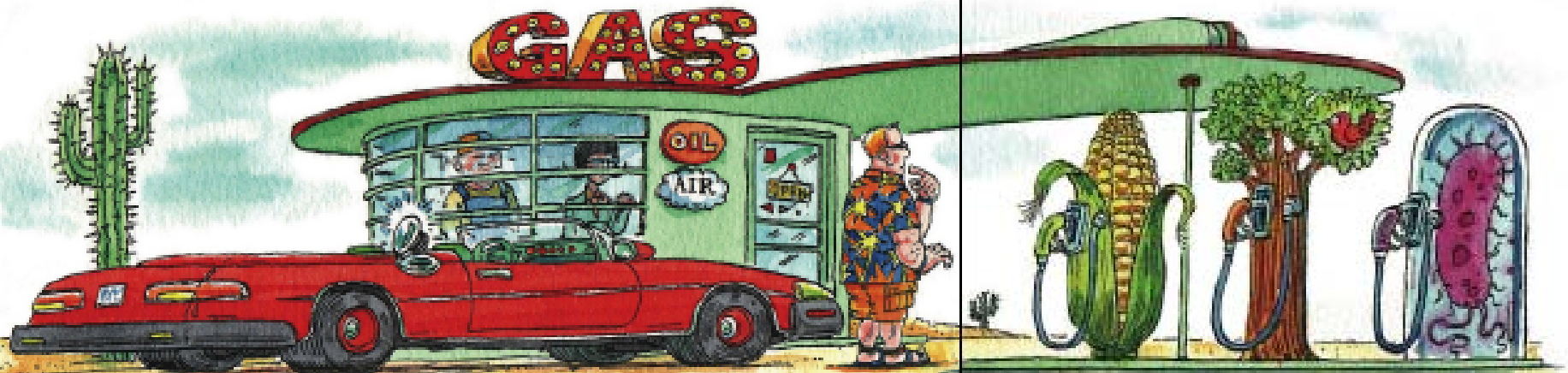



Cleaning up: Brazil's use of sugar cane, here being washed for refining, significantly reduces CO₂ emissions.



BIOFUELLING THE FUTURE



BRAZIL

~24 billion L fuel ethanol
 ~1(?) billion L of Cachaça

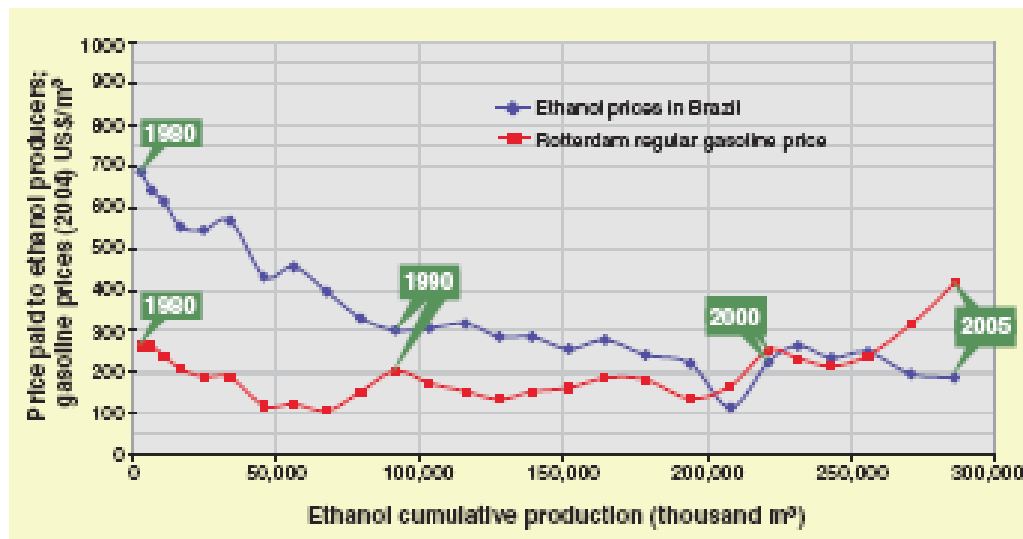



FLOW DIAGRAM – SUGAR AND ETHANOL

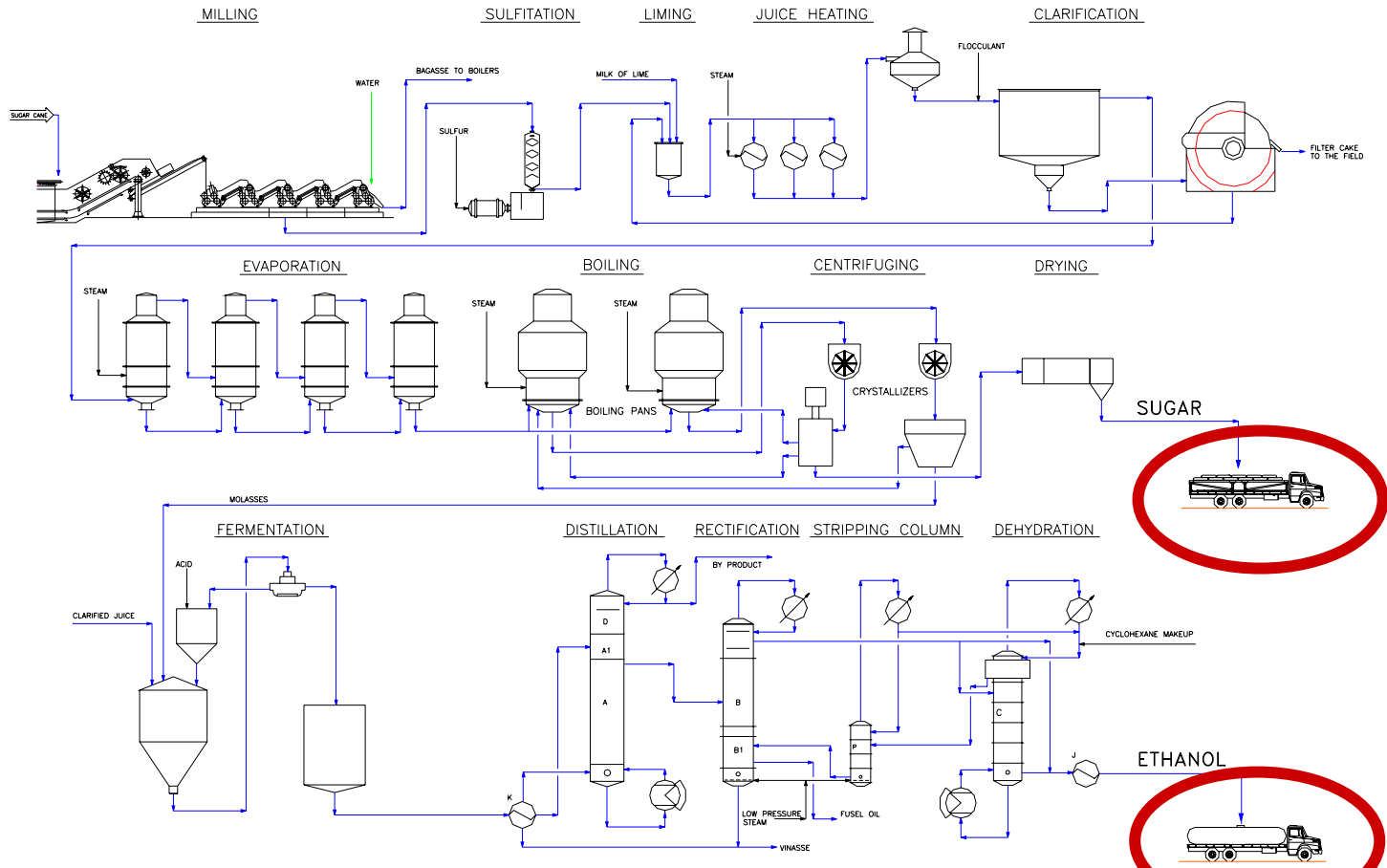

Ethanol Stoichiometric Yield(%)

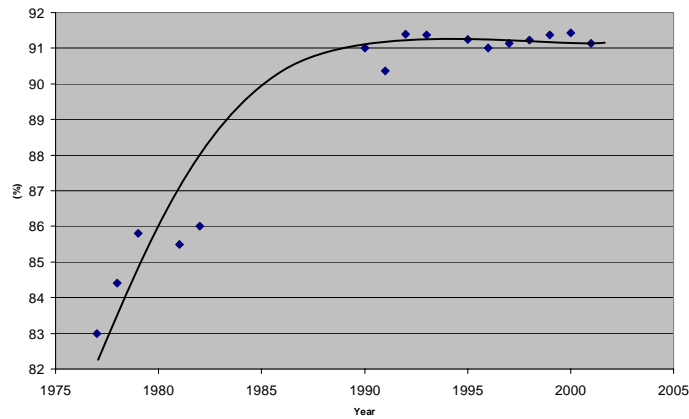

Fermentation Time(h)

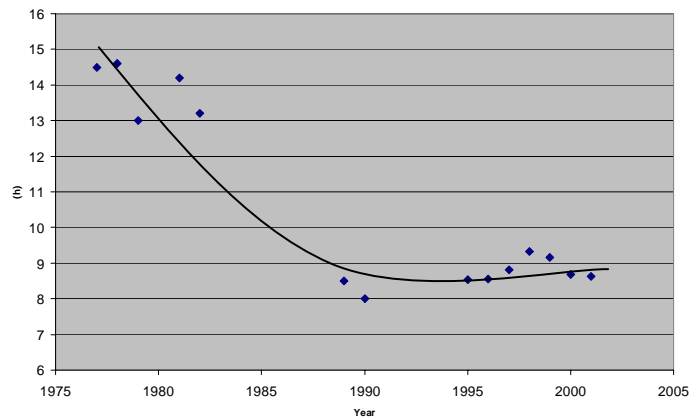

Main parameters:

- [sugar]: 180-200 g/L
- Final ethanol content: 9°GI (%vol)
- Final yeast concentration: 13% (~10⁹ cells/ml)
- Fermentation time: 6-11 h
- Fed-batch or continuous multistage with **cell recycle**
- Total fermenter capacity: 3000 m³
- Yield (stoichiometric): 91%
- Temperature: 34-36°C

(~March..... into..... ~October)

Yeast ?



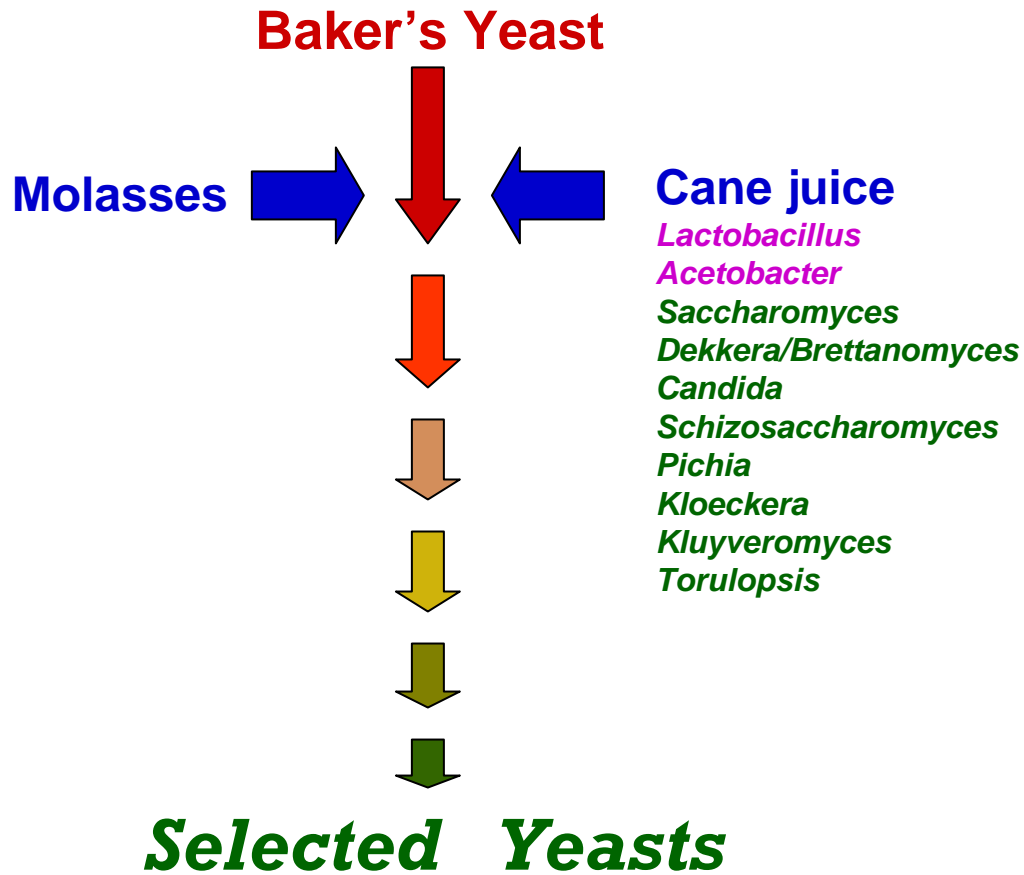

(Saccharomyces cerevisiae)

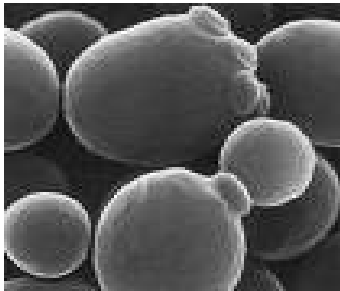

RESEARCH ARTICLE

Yeast selection for fuel ethanol production in Brazil

Luiz C. Basso¹, Henrique V. de Amorim², Antonio J. de Oliveira² & Mario L. Lopes²

¹Biological Science Department, Escola Superior de Agricultura Luiz de Queiroz, USP, Piracicaba, SP, Brazil; and ²Fermentec, Piracicaba, SP, Brazil

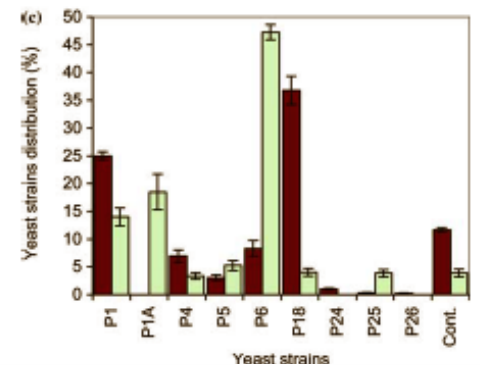
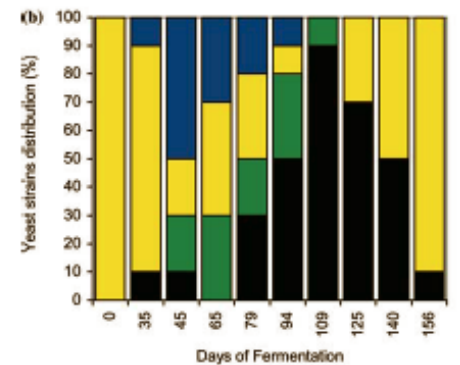
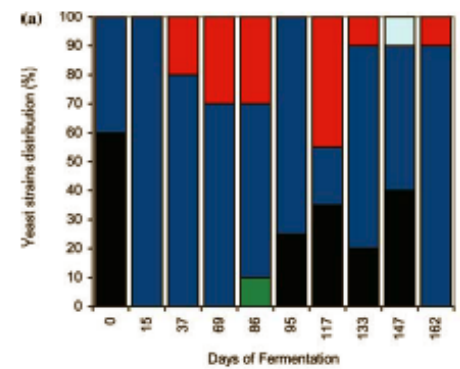
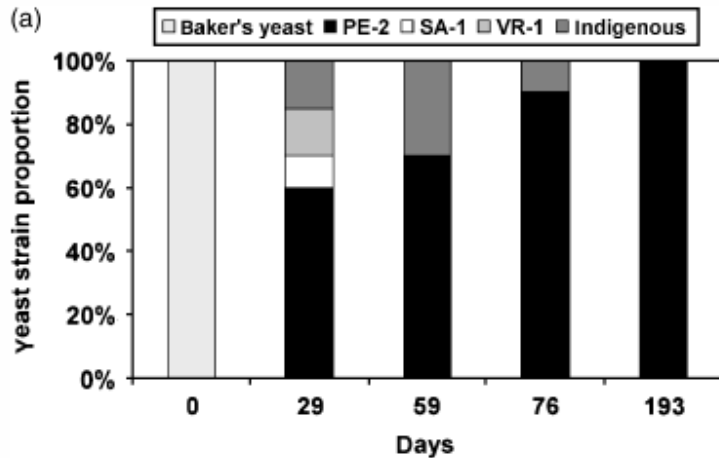

Use of selected indigenous *Saccharomyces cerevisiae* strains for the production of the traditional cachaça in Brazil

F.C.O. Gomes^{1,2}, C.L.C. Silva¹, M.M. Marini¹, E.S. Oliveira³ and C.A. Rosa¹

1 Departamento de Microbiologia, Instituto de Ciências Biológicas, Universidade Federal de Minas Gerais, Belo Horizonte, Minas Gerais, Brazil
 2 Departamento de Química, Centro Federal de Ensino Tecnológico, Belo Horizonte, Minas Gerais, Brazil
 3 Departamento de Alimentos, Faculdade de Farmácia, Universidade Federal de Minas Gerais, Belo Horizonte, Minas Gerais, Brazil

Journal of Applied Microbiology 103 (2007) 2438–2447

Antonie van Leeuwenhoek (2005) 88:13–23
 DOI 10.1007/s10482-004-7283-8

© Springer 2005

Yeast population dynamics of industrial fuel-ethanol fermentation process assessed by PCR-fingerprinting

Eurípedes Alves da Silva-Filho^{1,2}, Scheila Karina Brito dos Santos³, Alessandra do Monte Resende³, José Otamar Falcão de Moraes⁴, Marcos Antonio de Moraes Jr^{1,3,4} and Diogo Ardaillon Simões^{1,5}

S288c

Industrial Yeasts

Fermentec:
CAT-1; PE-2; VR-1
Copersucar:
BG; SA

>10 billion L ethanol / year

UFPE-135; UFPE-379

UFMG (cachaça):
829; 905; 1007; 2097; 2439

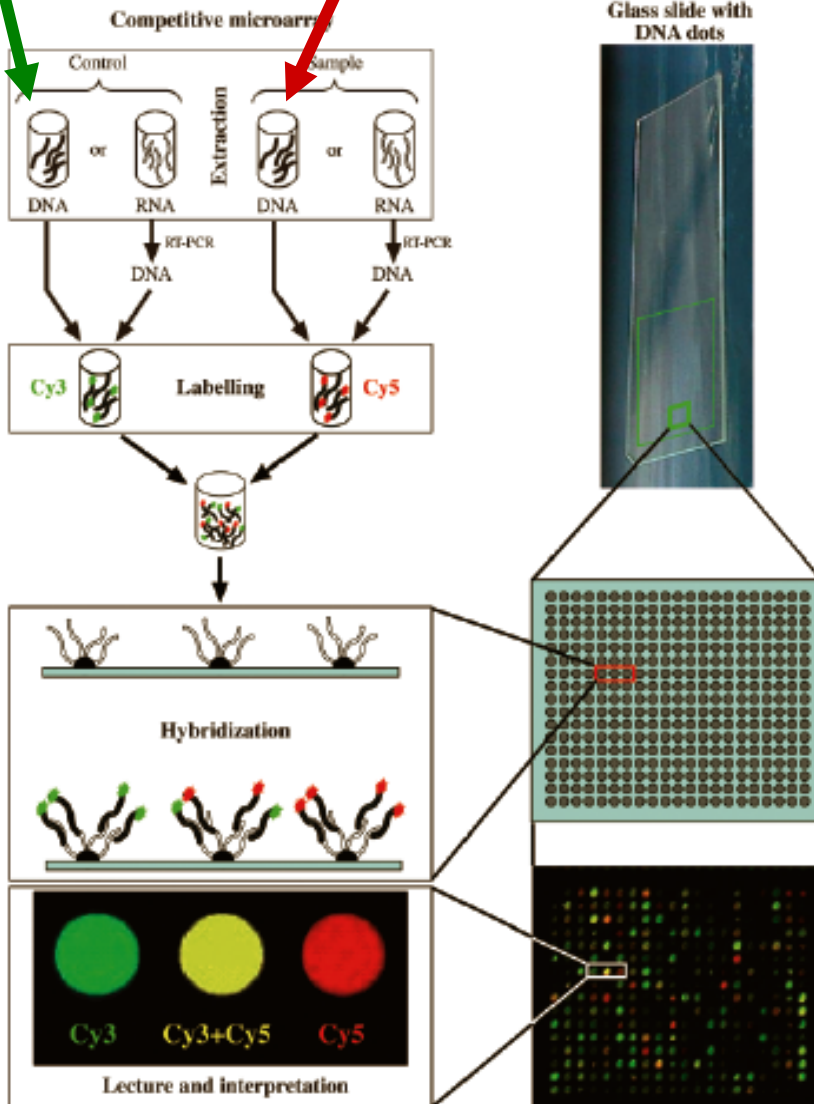

array-CGH
(microarray Comprehensive Genomic Hybridization)

Microarray Karyotyping



PE-2

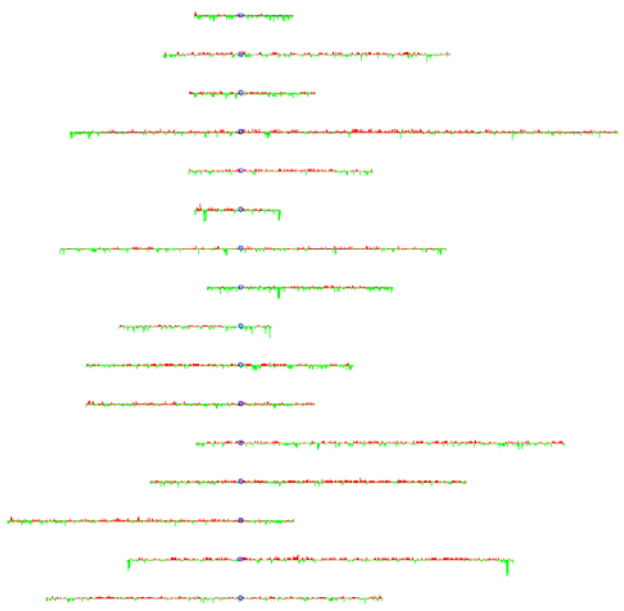

CAT-1

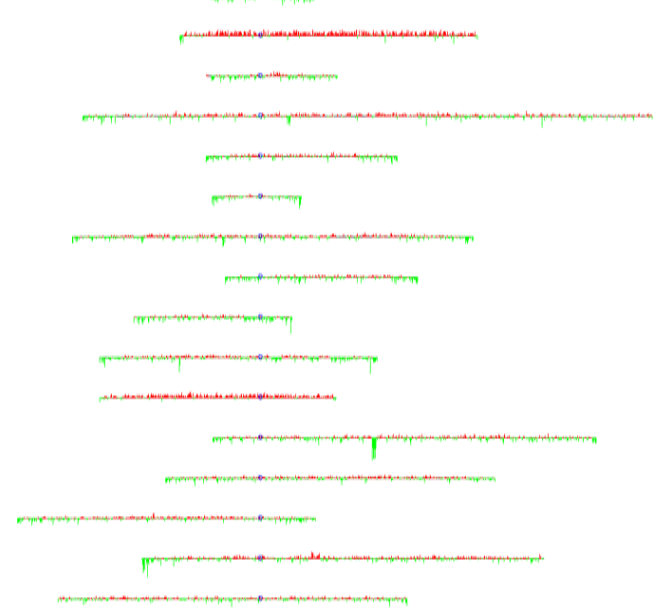

UFMG905

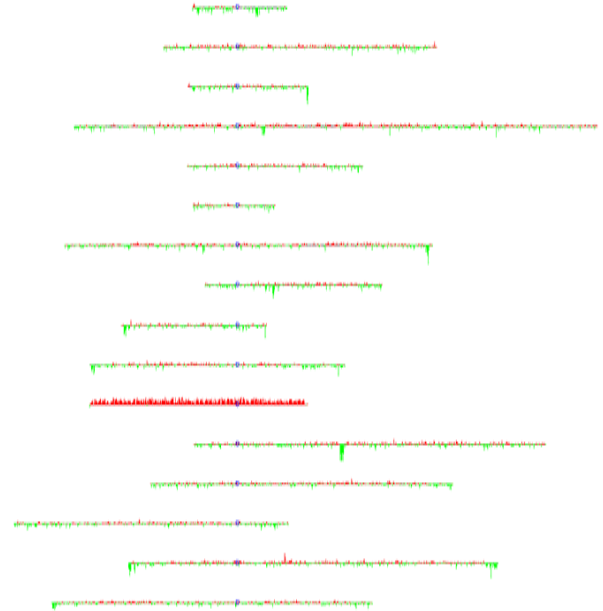

UFMG829

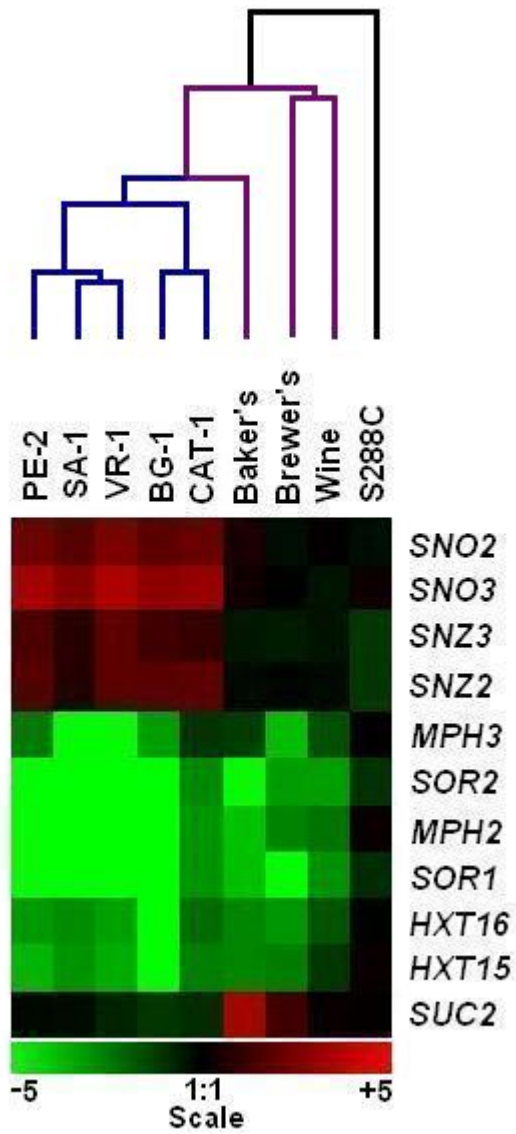

Pyridoxine (& Thiamin) biosynthesis

Glucose

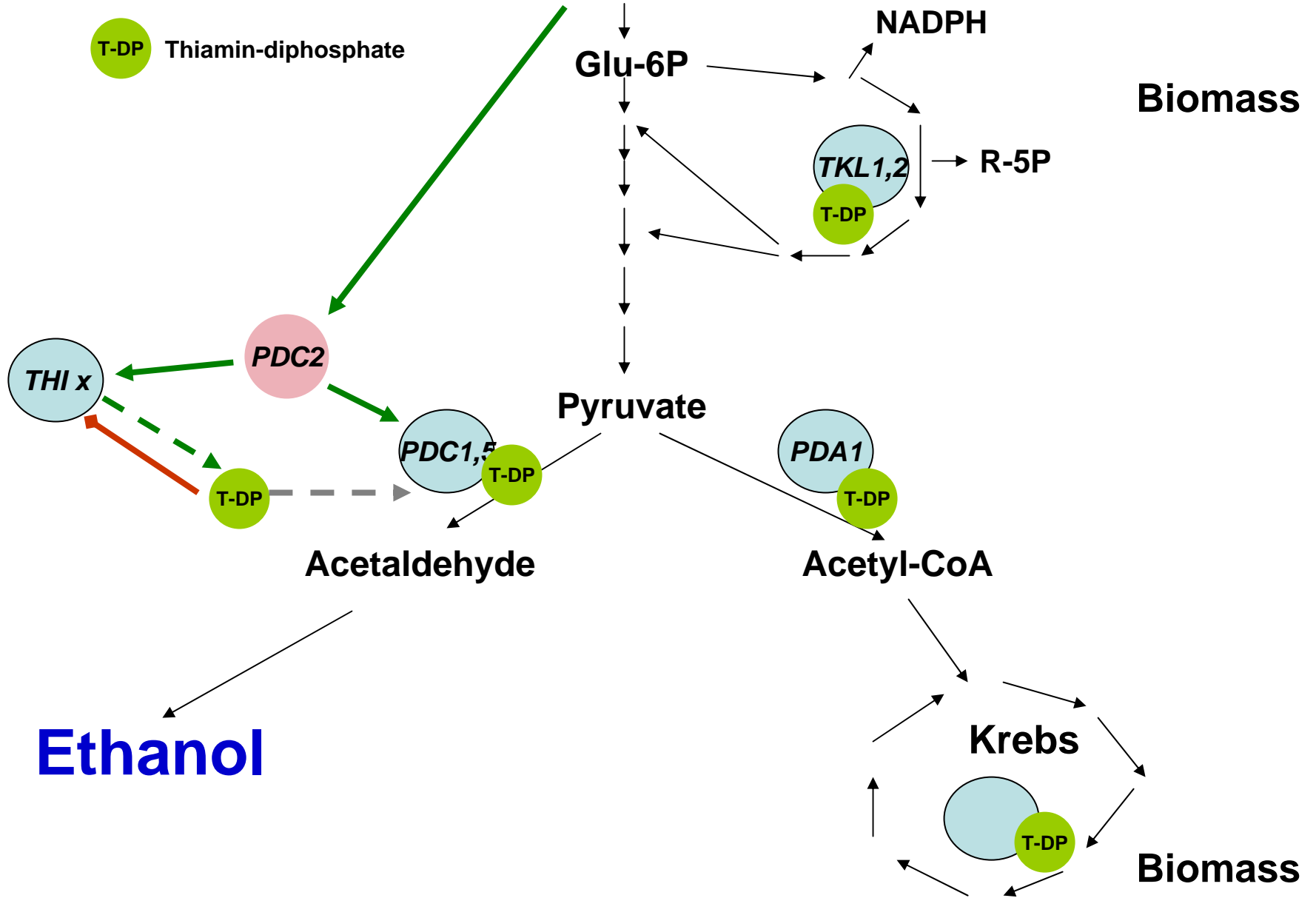

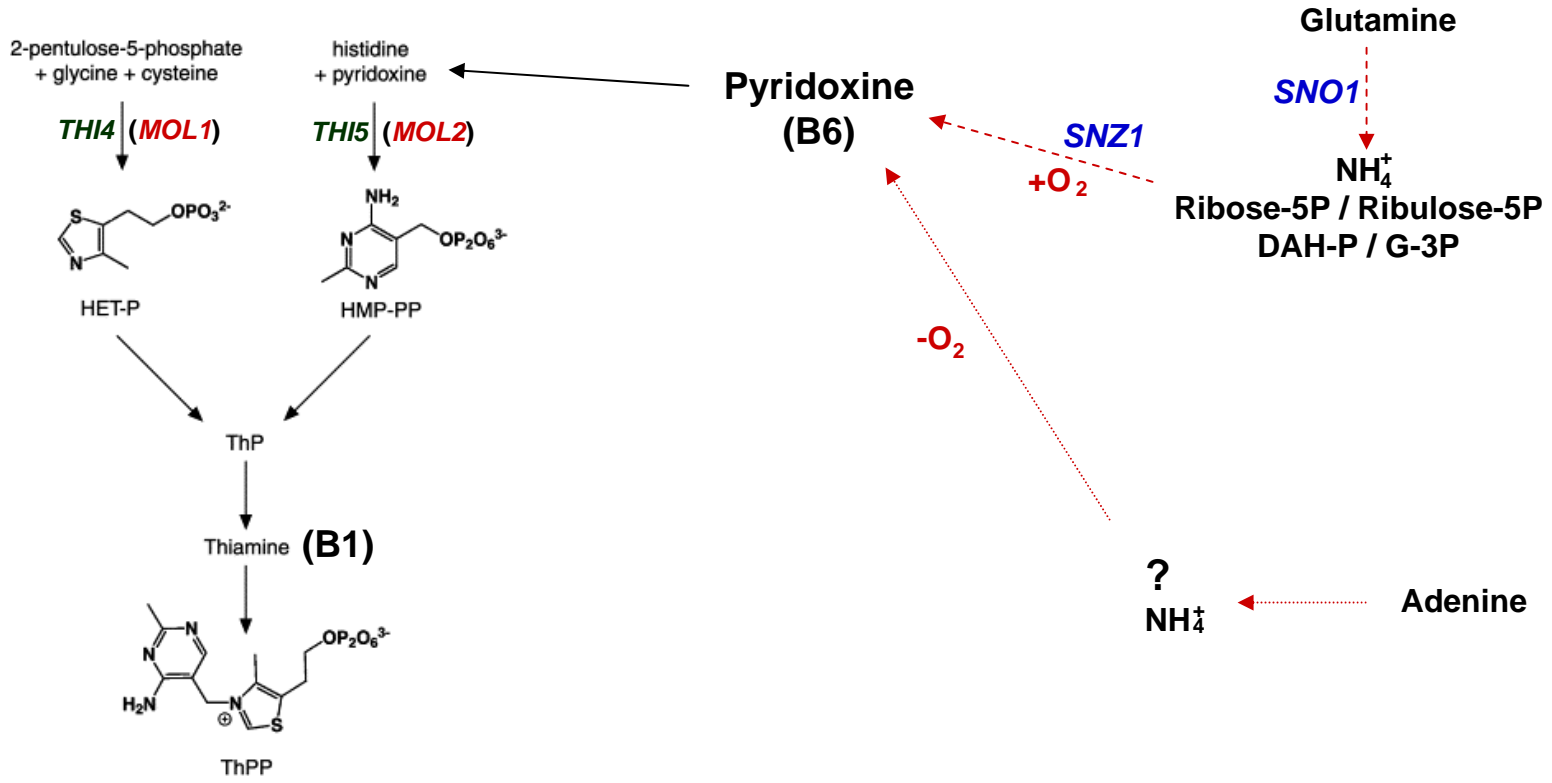

SNZ1 ~80%

SNZ2 / SNZ3

SNO1 ~72%

SNO2 / SNO3

diauxic shift
stationary phase

logarithmic (fermentative) phase
repressed by thiamin !

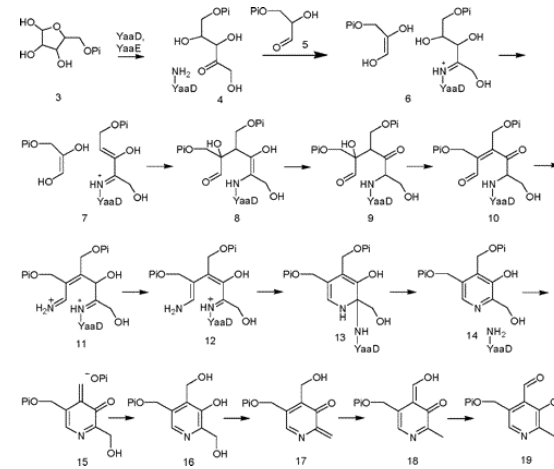
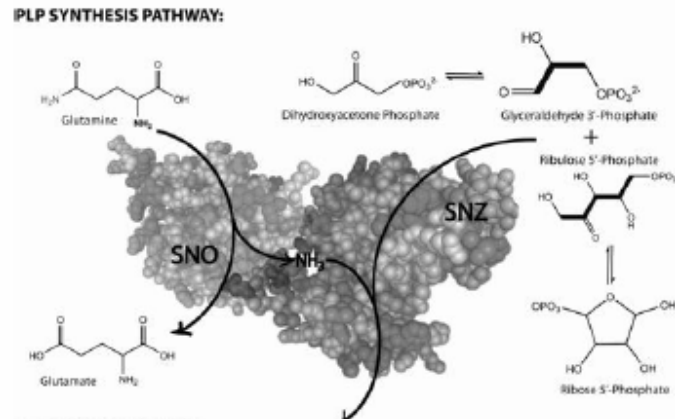
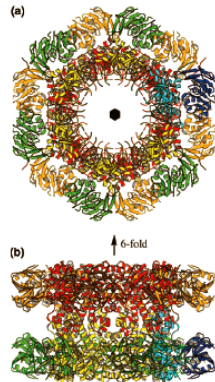

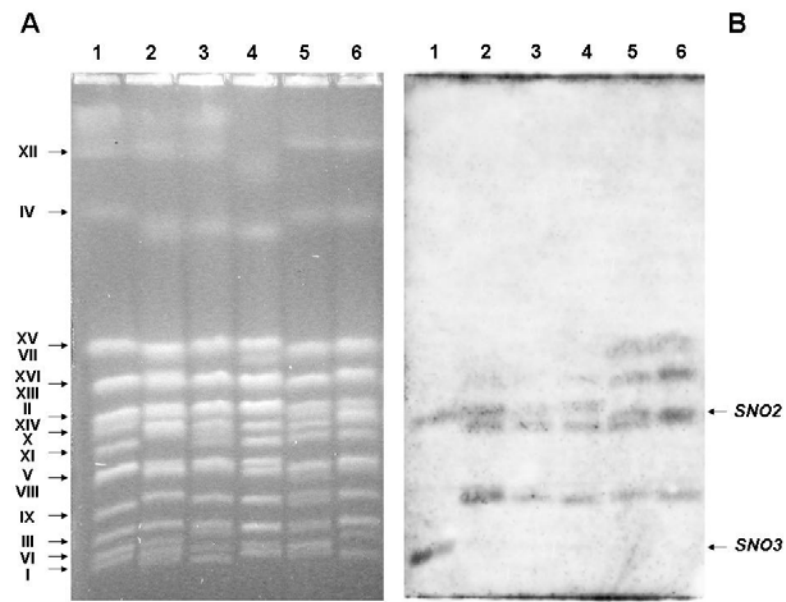
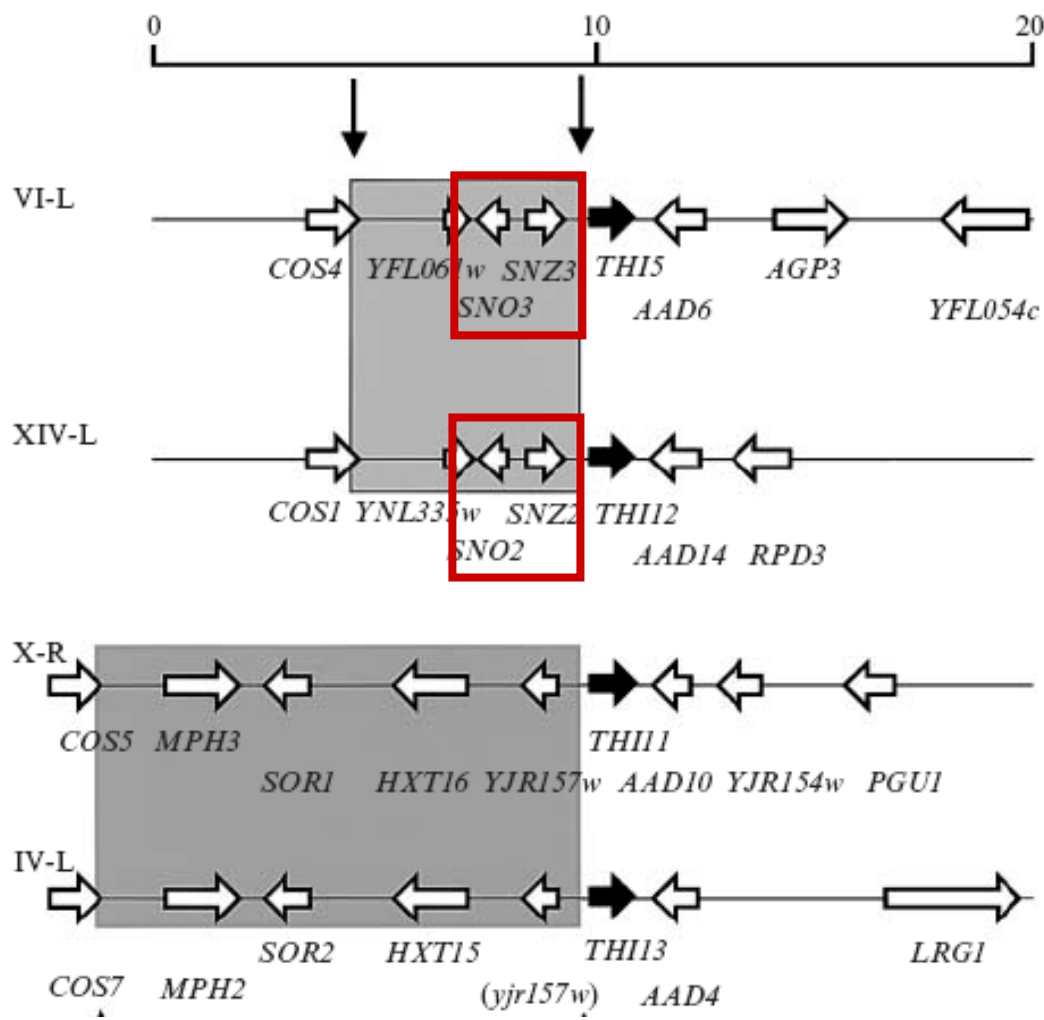

- +B1 -B6
- -B1 -B6
- -B1 +B6
- +B1 +B6

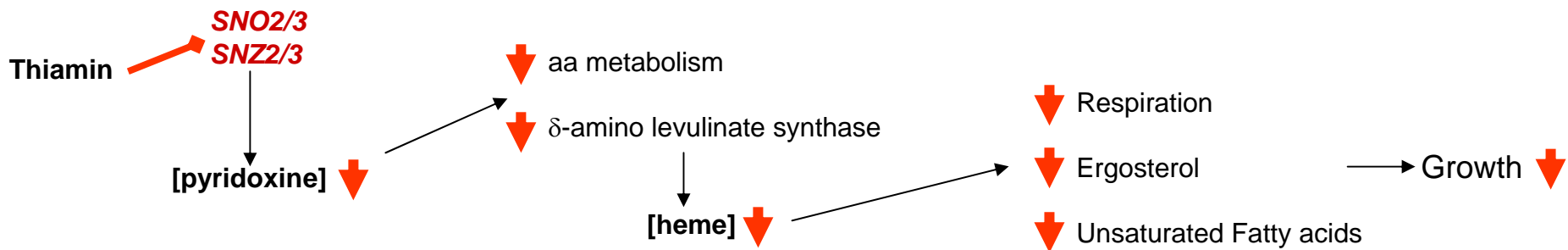
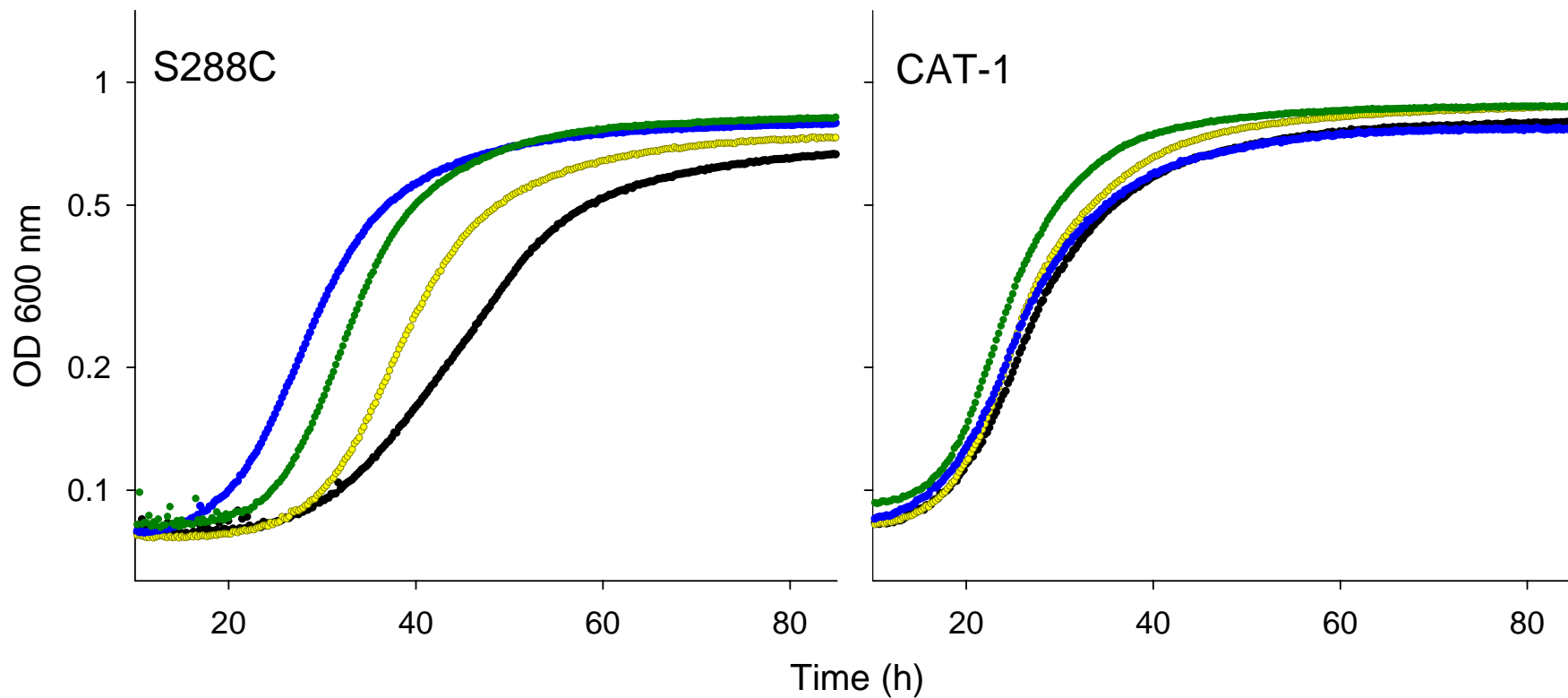

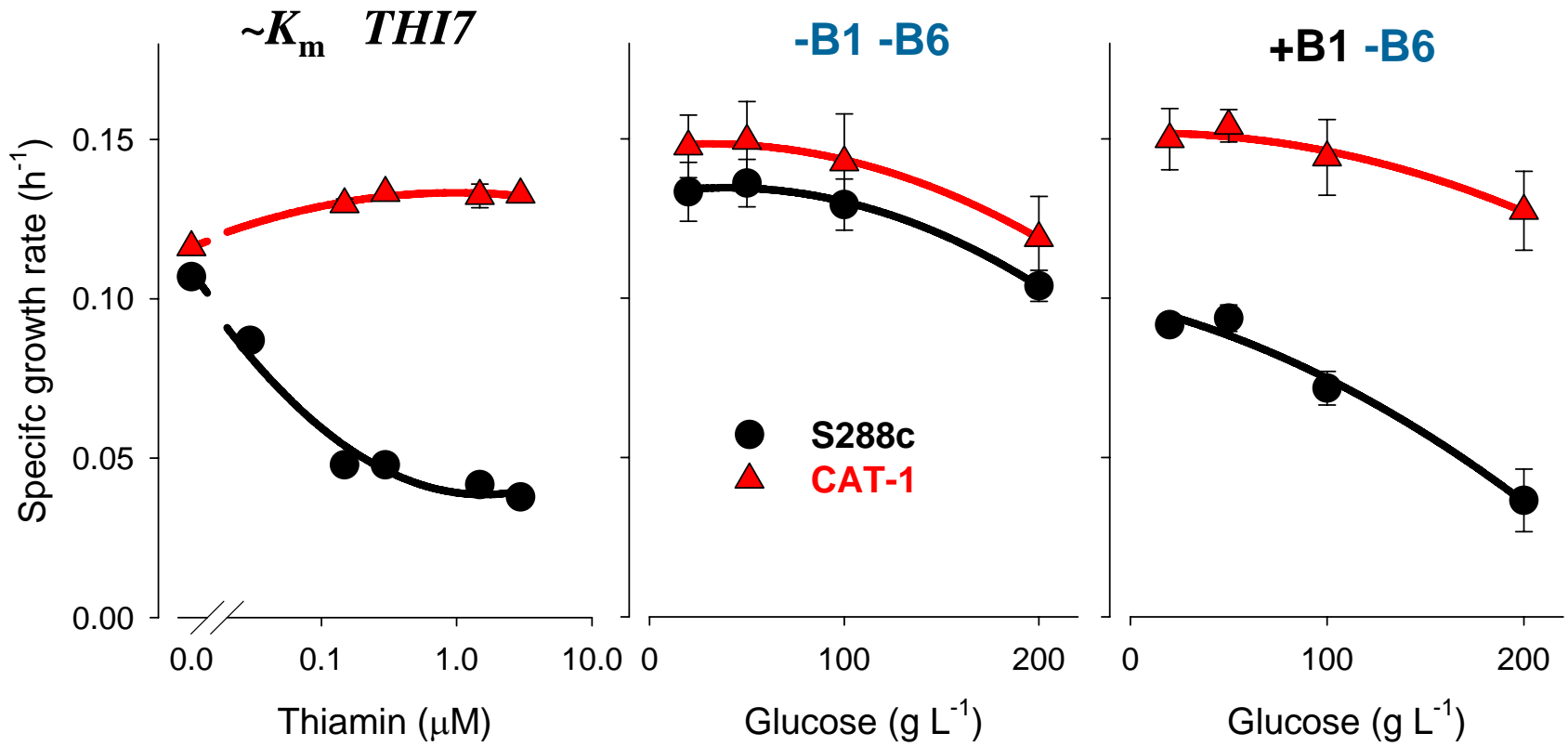

A phenotype important at high **[sugar]**

Direct competition

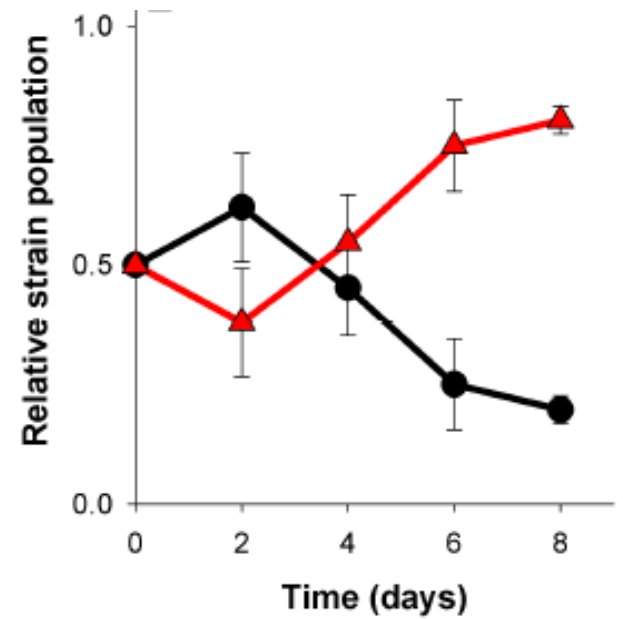
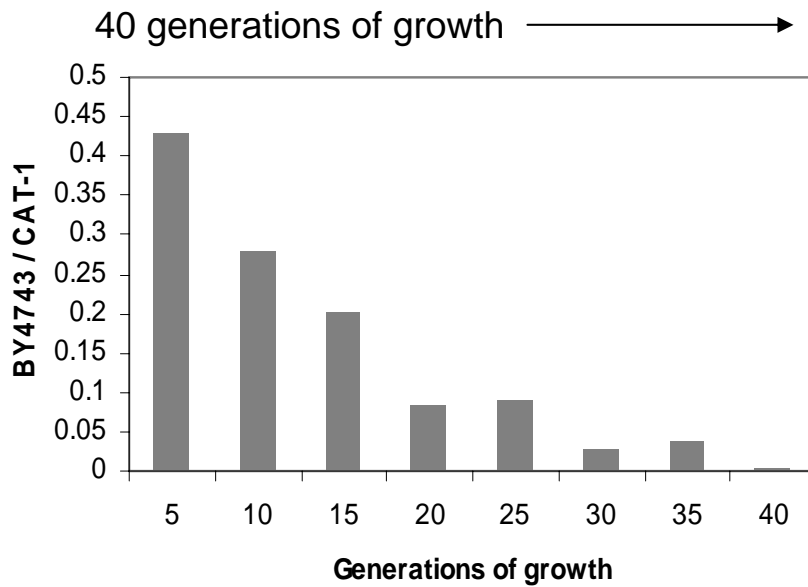
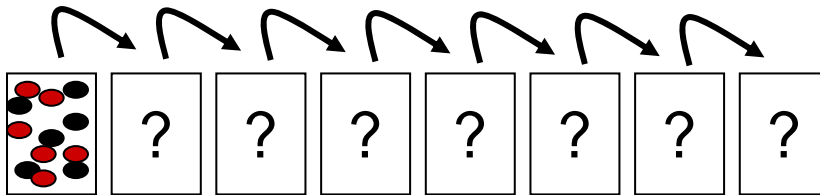



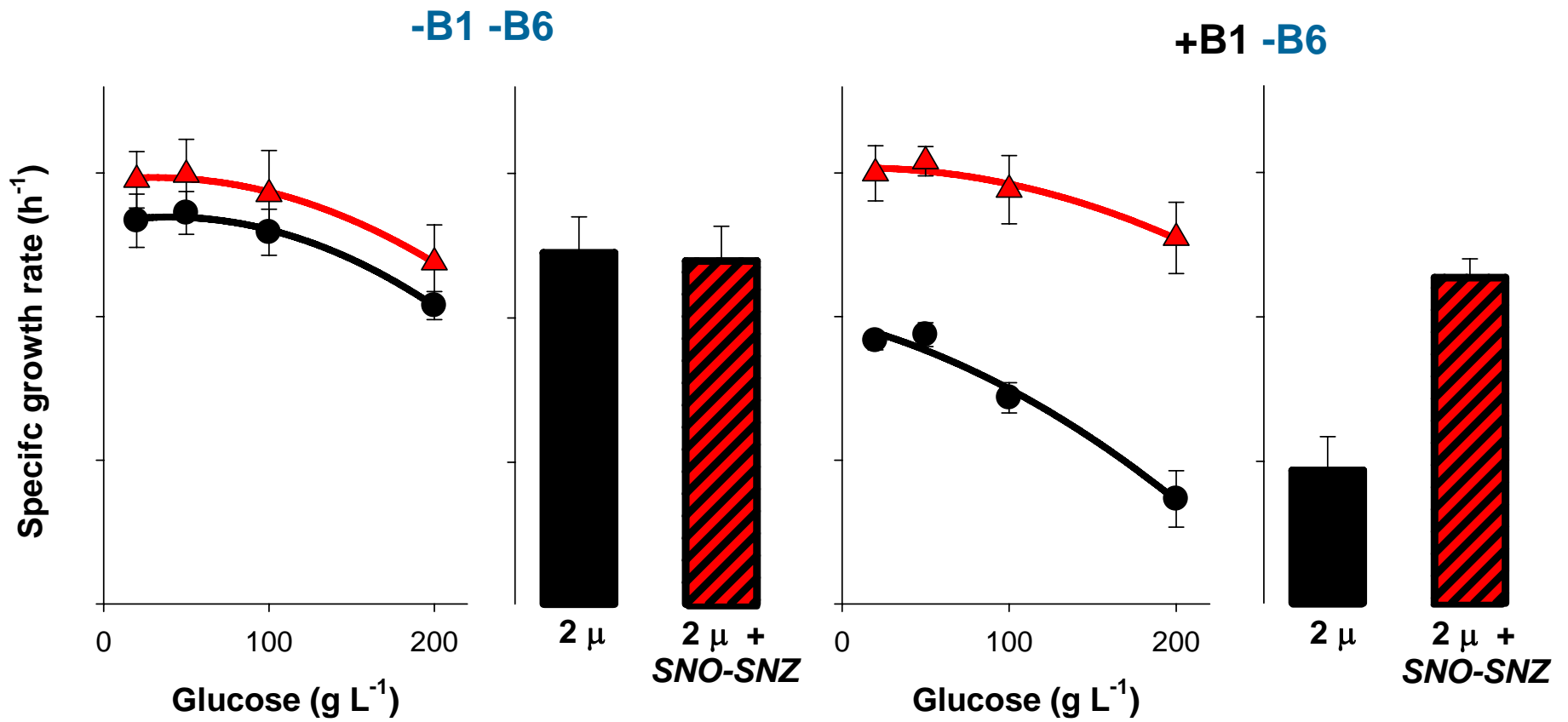

Industrial fuel ethanol yeasts contain adaptive copy number changes in genes involved in vitamin B1 and B6 biosynthesis

Boris U. Stambuk, Barbara Dunn, Sergio L. Alves, Jr, et al.

Genome Res. 2009 19: 2271-2278 originally published online November 6, 2009

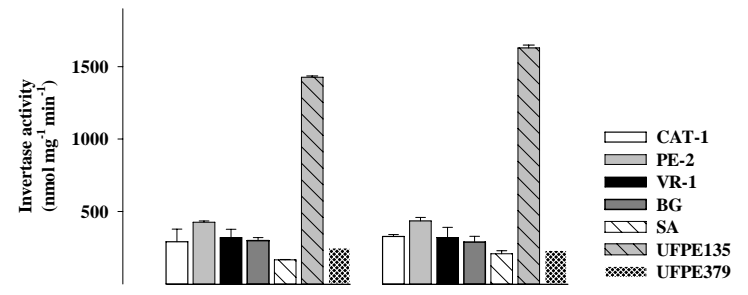
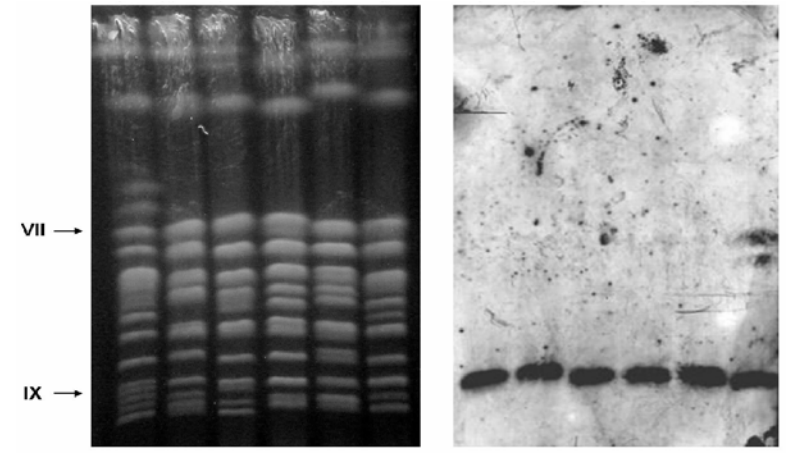
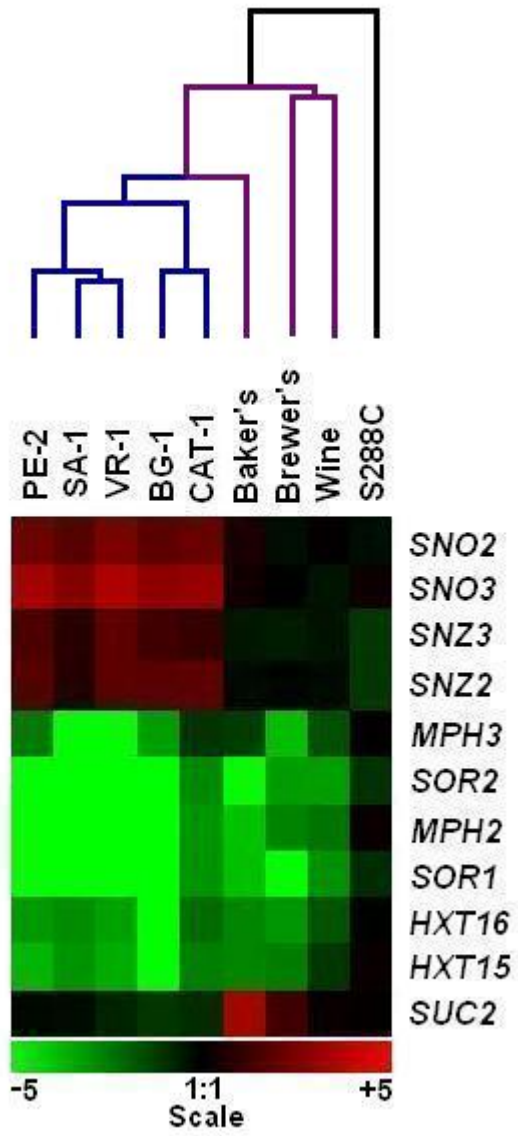

Summary and future developments.....

a-CGH

genomic differences

Fuel yeasts

selection and/or evolution ?

Pyridoxine / Thiamin

yeast performance

[sugar] 

vitamin supplementation ?

improve YEAST and/or sugar-cane B1 / B6
production ?

Other industrial yeasts ?

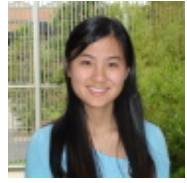

“Wet” lab



Dr. Gavin Sherlock

“Web” lab



Drs. A. Amorim & M.L. Lopes

Dr. J. Finguerut (CTC)



Dr. Carlos A. Rosa (UFMG)

Dr. Marcos A. Morais-Jr (UFPE)